

2.4M SINGLE SIDED WALL SYSTEM ERECTION STEP BY STEP GUIDE

IMPORTANT NOTES:

THIS DRAWING TO BE USED IN CONJUNCTION WITH TYPICAL 2.4M SINGLE SIDED WALL SYSTEM CROSS-SECTION AND ELEVATION VIEWS OR BESPOKE PROJECT DRAWINGS TO OBTAIN EXACT POSITIONING OF PUSH-PULL PROPS AND INTERMEDIATE BRACES.

THESE ARE STANDARD, GENERIC AND NOT SITE SPECIFIC FITTING INSTRUCTIONS FOR THE FAST FORM WALL SYSTEM, YOU SHOULD BE ABLE TO COMPLETE 2.4M OR LOWER AND ANY TYPE OF POUR FOLLOWING THESE:

1. START BY MARKING OUT THE LINE OF THE SHUTTER (REMEMBER TO DEDUCT THE PLYWOOD THICKNESS). DRILL A HOLE FOR THE CONCRETE HOLDING DOWN BOLT IN ACCORDANCE WITH BOLT MANUFACTURER TECHNICAL SPECIFICATIONS AND INSTALLATION GUIDE. FOR SINGLE SIDED FAST FORM WALL SYSTEM USE 2x CONCRETE BOLT PER UPRIGHT AND PER PROP'S FOOT. ALL CONCRETE BOLTS SHOULD BE TIGHTENED WITH A 110V IMPACT WRENCH.

IMPORTANT

2. ALWAYS START WORKING FROM THE INSIDE CORNER MOVING AWAY FROM IT [REFER TO DRAWING NO FFS-WSTC FOR MORE DETAILS].

3. THE HORIZONTAL JOINING MEMBERS ARE USED TO SET THE DISTANCE BETWEEN THE UPRIGHTS AND THIS WILL REMAIN CONSTANT ONCE SET [1220MM CENTRE TO CENTRE OF UPRIGHTS] SO YOU CAN MARK AND DRILL ALL THE HOLES AHEAD OF YOU.

4. WHEN INSERTING THE HORIZONTAL JOINING MEMBERS DO NOT TIGHTEN UNTIL ALL HAVE BEEN FITTED LOOSELY FIRST.

5. WORK ALONG A SECTION AT A TIME, TIGHTENING AS YOU GO, YOU CAN FIX THE PLYWOOD AS YOU GO. THE PLYWOOD CAN BE FITTED HORIZONTALLY OR VERTICALLY AND IS FIXED FROM BEHIND WITH 25MM STANDARD WOOD SCREWS. IF THE REBAR IS ALREADY FIXED IT MAY BE EASIER TO FIX THE PLYWOOD HORIZONTALLY AND FIX BOTH BOTTOM SIDES BEFORE MOVING UP AS THIS WILL ALLOW MORE ROOM TO WORK.

6. WISAFORM MDO PLYWOOD, IF SUPPLIED BY FAST FORM SYSTEMS, THE LIGHT BROWN FACE IS THE FACE TO USE FOR THE CONCRETE SIDE, NOT THE DARK BROWN FACE. ALL PLYWOOD SHOULD BE SUITABLY OILED FOR EASY RELEASE AFTER CONCRETING.

7. ONCE ERECTED, PANELS CAN BE LIFTED AND MOVED. THE SYSTEM DOES NOT HAVE TO BE DISMANTLED AND RE-ERECTED EVERY TIME. BEFORE CONDUCTING A LIFT PLEASE CONSULT WITH FAST FORM SYSTEMS! A COMPETENT PERSON SHOULD SUPERVISE THE LIFTS AND ONLY SUITABLE LIFTING EQUIPMENT SHOULD BE USED.

8. IF ACCESS AND HANDRAILS HAVE BEEN REQUESTED BY THE CLIENT, THEY SHOULD BE FITTED BY A COMPETENT PERSON AND MADE SECURE BEFORE BEING USED AS A PLATFORM. THE ACCESS IS NOT LOAD BEARING AND SHOULD NOT BE USED FOR ANYTHING OTHER THAN ACCESS FOR CONCRETE POURING [REFER TO DRAWINGS NO FFS-APHR# FOR MORE DETAILS].

9. IF IN DOUBT OF ANYTHING PLEASE CALL OUR OFFICE, WE ARE HERE TO HELP.

CORRECT POSITIONING OF CONCRETE BOLTS

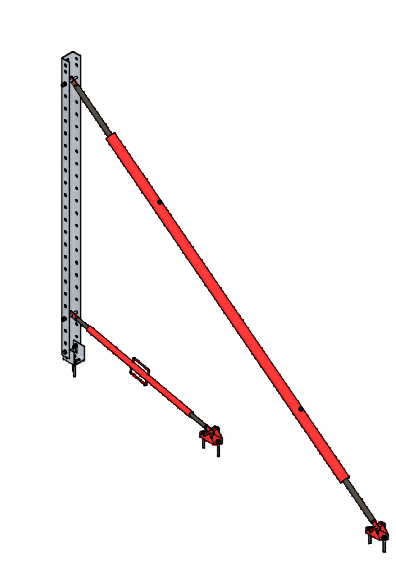

STEP ONE:
DRILL AND FIX FIRST UPRIGHT TO THE LINE OF THE WALL MINUS THE PLYWOOD THICKNESS. FOLLOW BOLT MANUFACTURER TECHNICAL SPECIFICATIONS AND INSTALLATION GUIDES TO PROPERLY SECURE THE CONCRETE BOLTS. EACH PUSH/PULL PROP TO BE SECURED ON INDIVIDUAL FOOT. TWO CONCRETE BOLTS PER EACH INDIVIDUAL FOOT TO BE USED.

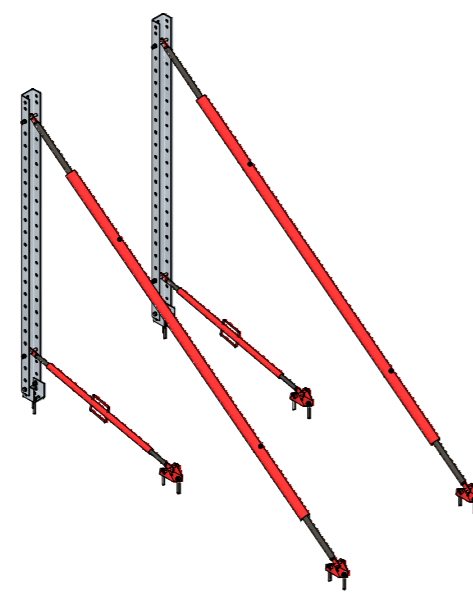

STEP TWO:
REPEAT FOR THE NEXT UPRIGHT USING THE HORIZONTAL BRACE TO SET THE DISTANCE APART.

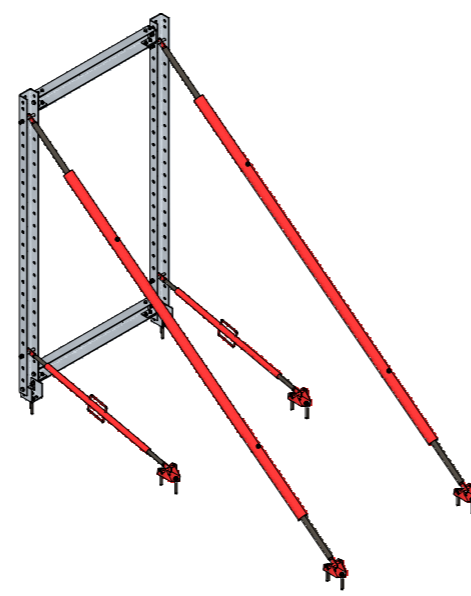

STEP THREE:
LOOSELY BOLT BOTTOM AND TOP HORIZONTAL JOINING MEMBERS USING THE CORDLESS IMPACT WRENCH.

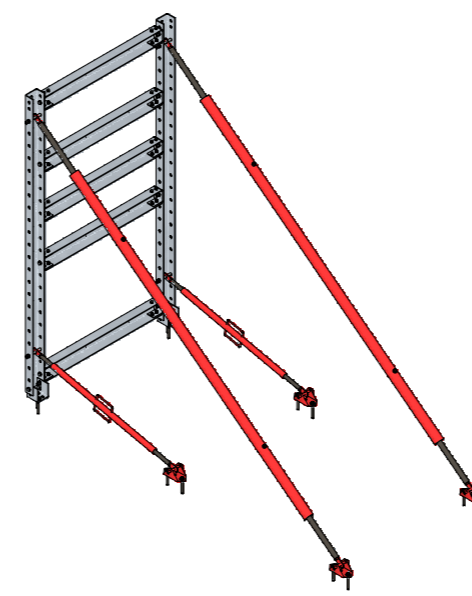

STEP FOUR:
FILL IN REMAINING HORIZONTAL JOINING MEMBERS.

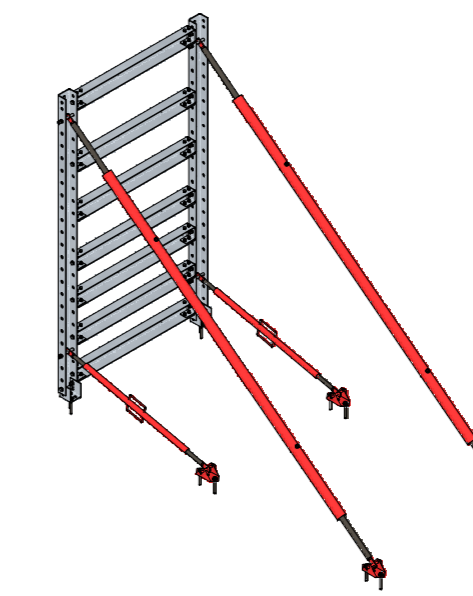

STEP FIVE:
TIGHTEN ALL BOLTS AND PLUMB THE UPRIGHTS. PLUMB UP THE UPRIGHTS USING A SPIRIT LEVEL AND ALTERING BY TURNING THE PUSH-PULL PROP ONE WAY OR THE OTHER

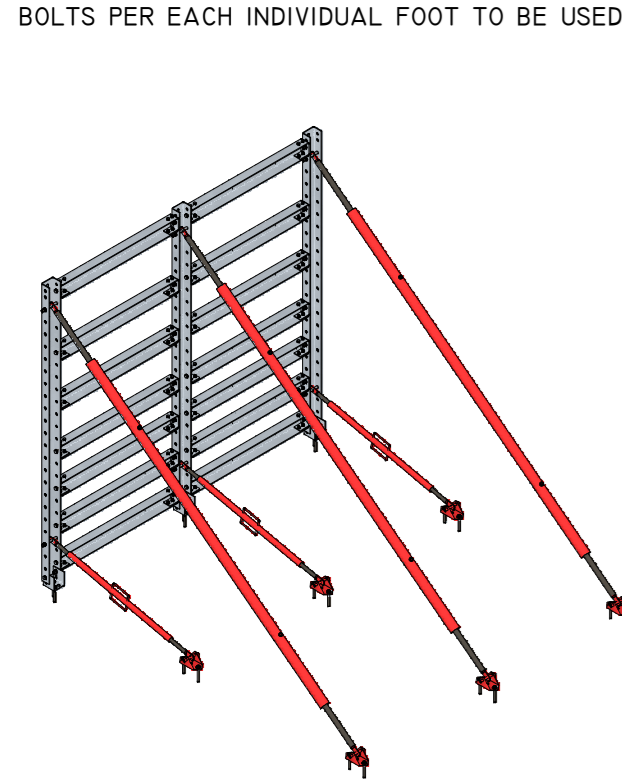

STEP SIX:
REPEAT THE PROCESS FOR NEXT UPRIGHTS.

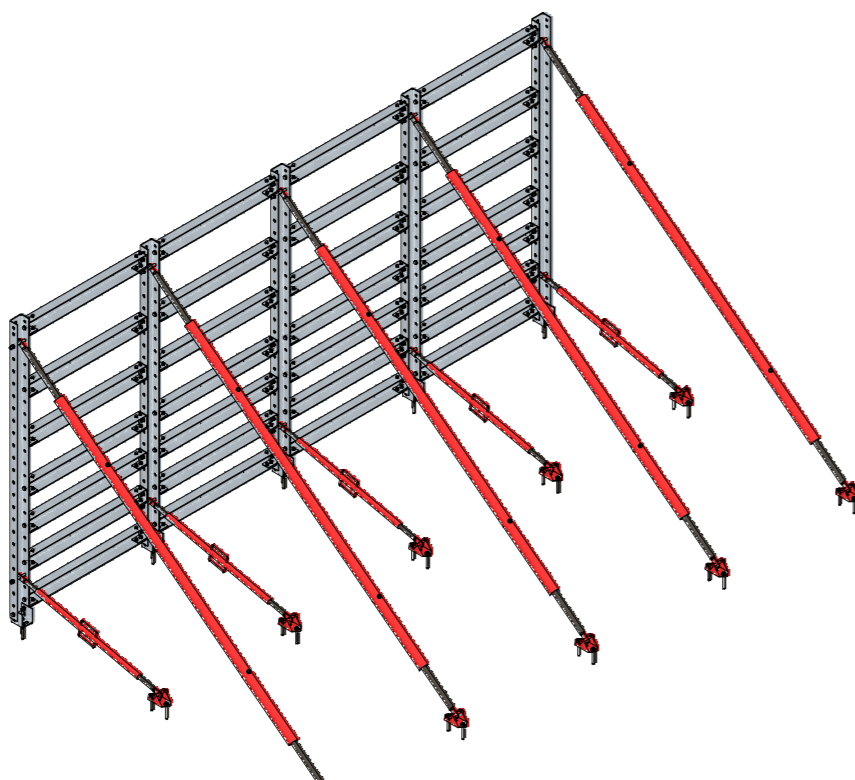

STEP SEVEN:
REPEAT THE PROCESS FOR NEXT UPRIGHTS UNTIL ALL ARE FIXED.

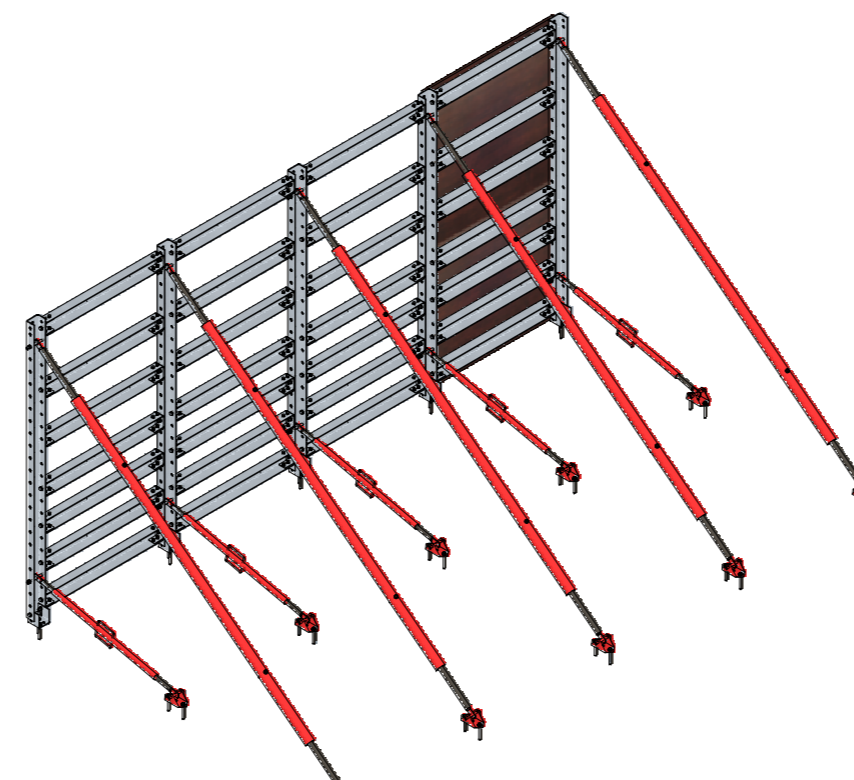

STEP EIGHT:
START FIXING THE PLYWOOD SECURING IT FROM BEHIND USING 25MM WOOD SCREWS. MAKE SURE THE PLYWOOD JOINTS FALL ON THE CENTRE OF THE UPRIGHTS OR THE HORIZONTAL JOINING MEMBERS.

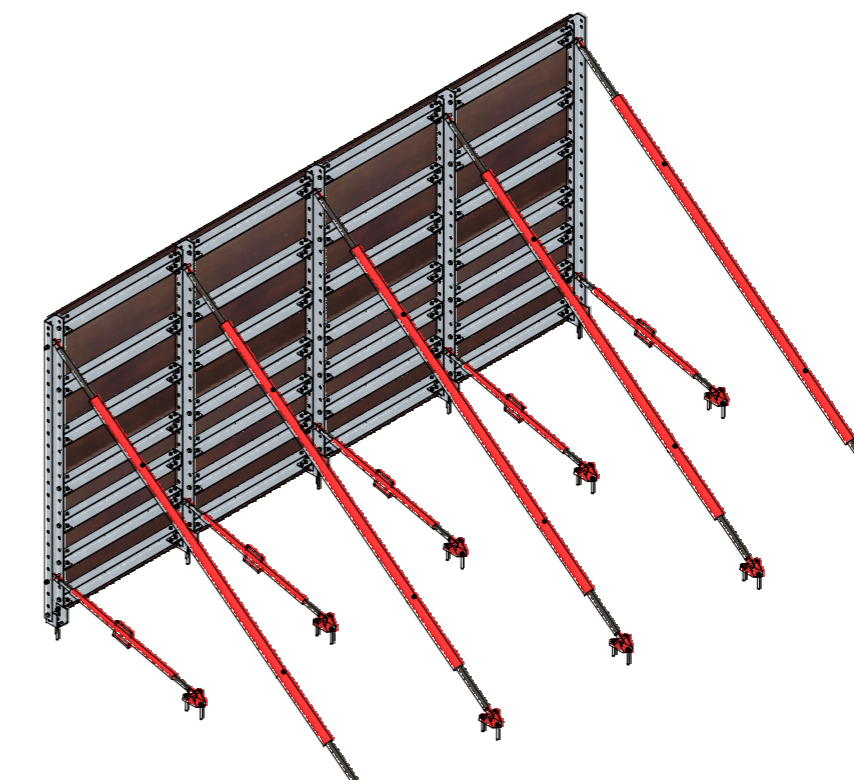

STEP NINE:
REPEAT THE PROCESS FOR THE WHOLE LINE OF THE WALL. ONCE ALL THE PLYWOOD IS FIXED LINE IN AND PLUMB UP THE WHOLE PANEL.

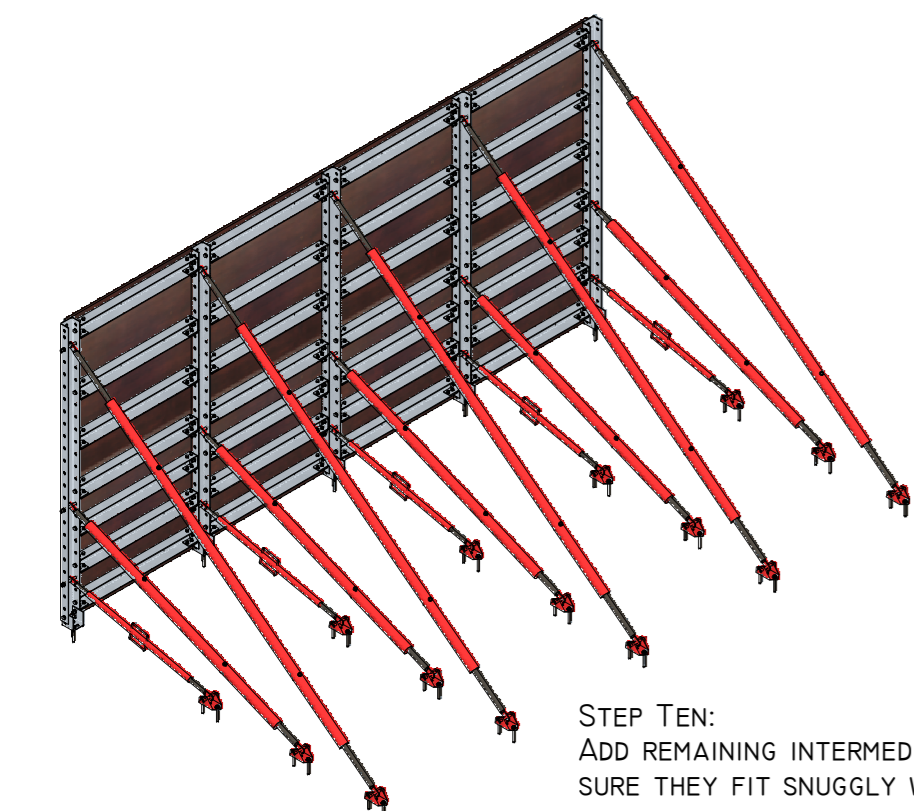

STEP TEN:
ADD REMAINING INTERMEDIATE PROPS, MAKING SURE THEY FIT SNUGGLY WITHOUT APPLYING FORCE IN EITHER DIRECTION.

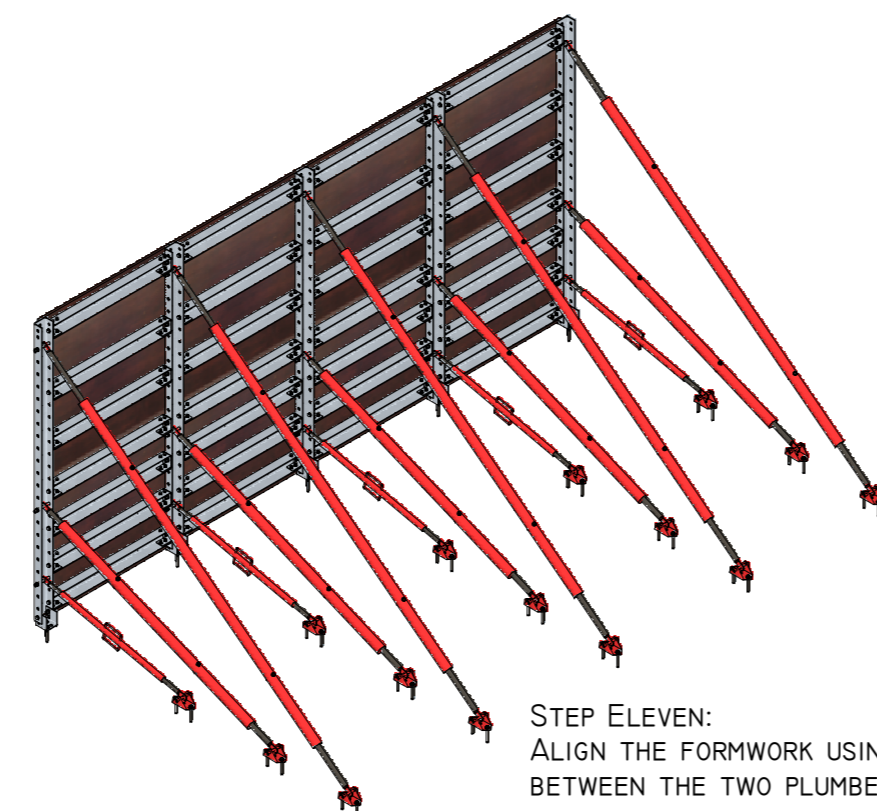

STEP ELEVEN:
ALIGN THE FORMWORK USING A STRAIGHT LINE BETWEEN THE TWO PLUMBED ENDS WHILE ADJUSTING THE TOP PROPS TO SUIT.

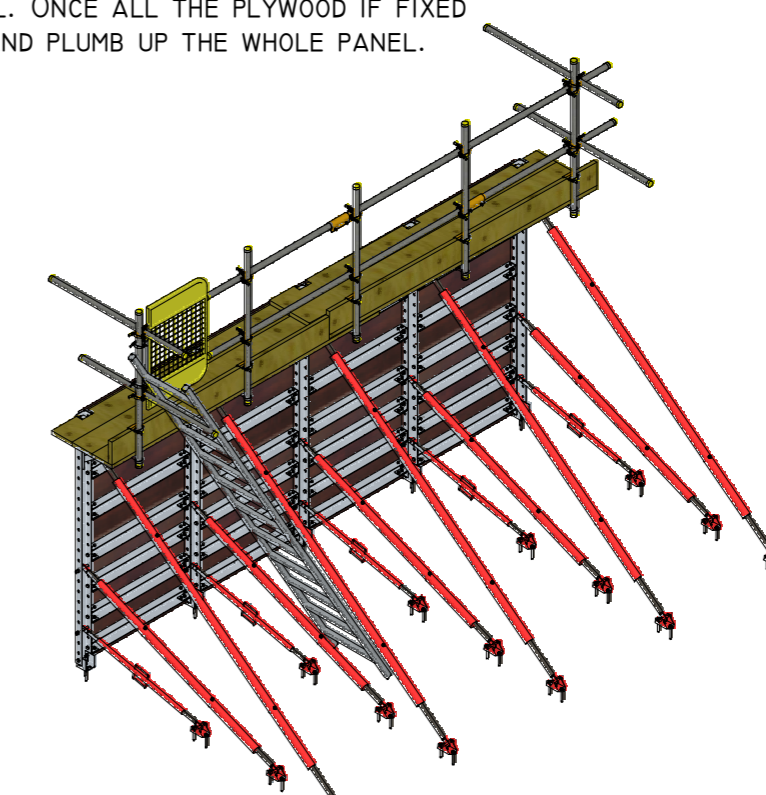

STEP TWELVE:
FIX HANDRAILS / ACCESS IF REQUIRED [REFER TO DRAWINGS FFS-APHR# FOR MORE DETAILS].

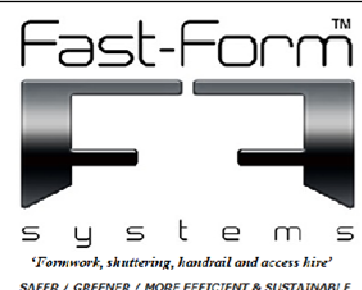

www.fastformsystems.com

info@fastformsystems.com

Tel South: 00 44 (0) 203 507 1832 / 507 1833 / 507 1834

Tel North: 00 44 (0) 1472 488230 / 488660 / 485640



Head Office:

Unit 1
Omega Business Park
Estate Road 6
Grimsby
N.E.Lincs
DN31 2TG

Legal Notice:

Fast Form™ is the Trade Mark of Fast-Form Systems Ltd and all designs are copyright and intellectual property of Fast Form Systems Ltd and may not be reproduced or used without permission.

Fast Form™ is covered by the following Patents: granted GB2508263 / GB2533172 Patents Pending GB 1616005.3 / GB 1506126.0 / US-2016-0194887 / PCT WO2016 / 110663 / EP 14780541.0 / PCT GB2014 / 052586.

Copyright or Trade Mark infringements will be prosecuted, If you see any similar system in operation without our name on it please send us an email to info@fastformsystems.com, we offer a reward for all successful prosecutions.

Drawn By: Karol Podsiadlo **Date:** 05/06/15 **Rev:** A

Designed by: Karol Podsiadlo **Drawing no:** FFS-24SSWSEG

Project: Fast Form Wall System

Drawing title: 2.4m Single Sided Wall System Erection Step by Step Guide