

150/200MM-2440MM RIGID ROAD FORM SYSTEM ERECTION STEP BY STEP GUIDE

IMPORTANT NOTES

TIMBER PROPS MAY BE REQUIRED TO ALIGN THE ROAD FORM PANELS [DESIGNED AND SUPPLIED BY CLIENT].

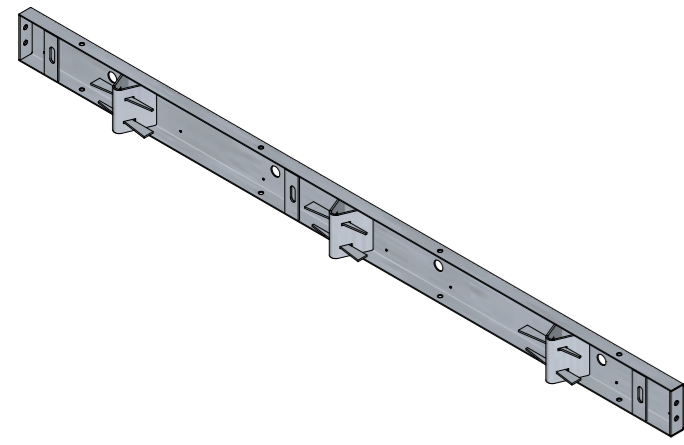

STEP ONE:
PULL A STRING FROM CORNER TO CORNER OF THE POUR TO GET A STRAIGHT PROFILE. IF USING PLYWOOD ON THE ROAD FORM REMEMBER TO ACCOUNT FOR PLYWOOD THICKNESS. PLACE A ROAD FORM PAN AT THE CHOSEN START POINT ALONG THE STRING.

IMPORTANT

IF THE POUR REQUIRES THE ROAD FORM PANS TO BE STACKED ON TOP OF EACHOTHER TO ACHIEVE A DESIRED POUR HEIGHT PROCEED TO THE BOTTOM OF THIS GUIDE; 'STACKING ROAD FORM PANS GUIDE' AND ONLY ONCE THIS STEP HAS BEEN COMPLETED PROCEED WITH STEP 1 ONWARDS.

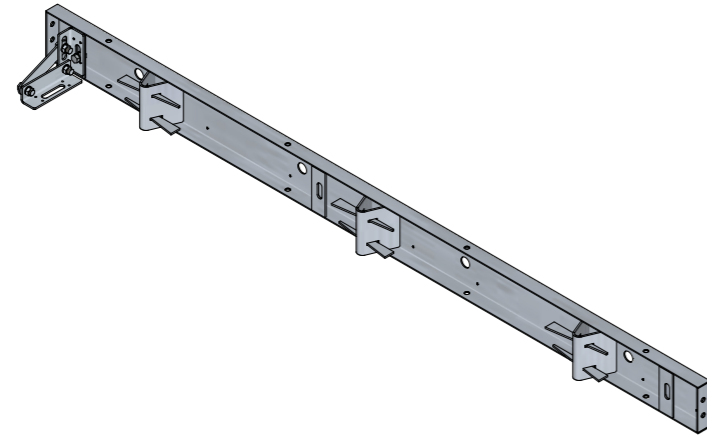

STEP TWO:
PLACE A ROAD PIN BETWEEN PIN BRACE AND WEDGES, CAREFULLY DRIVING INTO THE GROUND USING INSULATED LUMP HAMMER OR SLEDGE HAMMER. THE ROAD PIN MUST BE DRIVEN INTO THE GROUND SO THE ROAD FORM PAN IS SECURELY GROUNDED. MAKE SURE TO LEAVE ENOUGH ROAD PIN OVERHANG SO IT CAN BE EXTRACTED USING AN EXTRACTION TOOL.

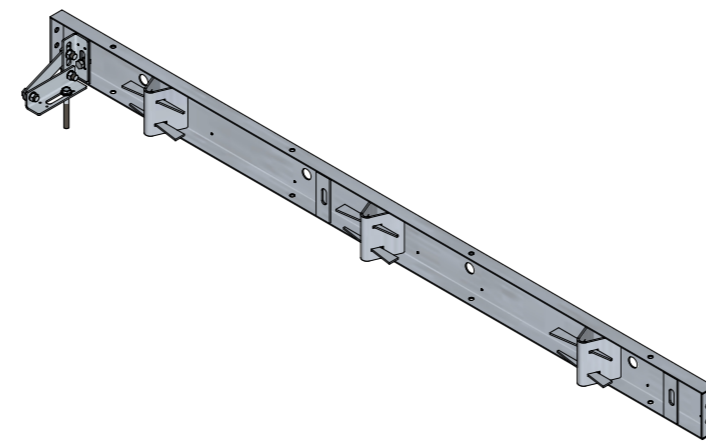

STEP THREE:
TIGHTEN THE GRIP ON THE ROAD PIN BY TAPPING IN THE WEDGES USING A CLAW HAMMER.

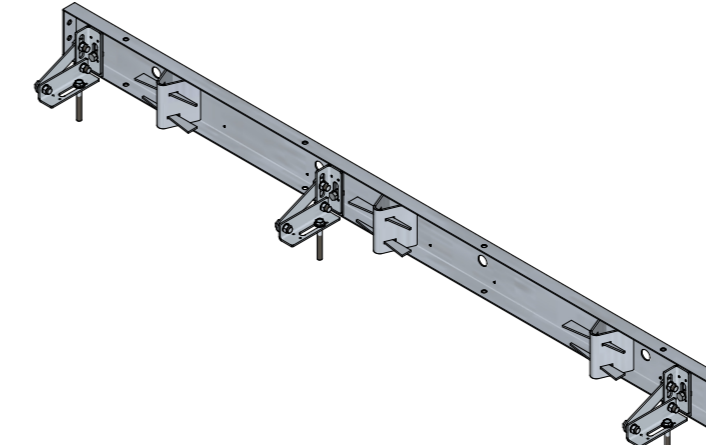

STEP FOUR:
REPEAT THE PROCESS FOR THE REMAINING PINS. THIS PROCESS SHOULD MAKE ROAD FORM PAN SECURED AND GROUNDED IN PLACE.

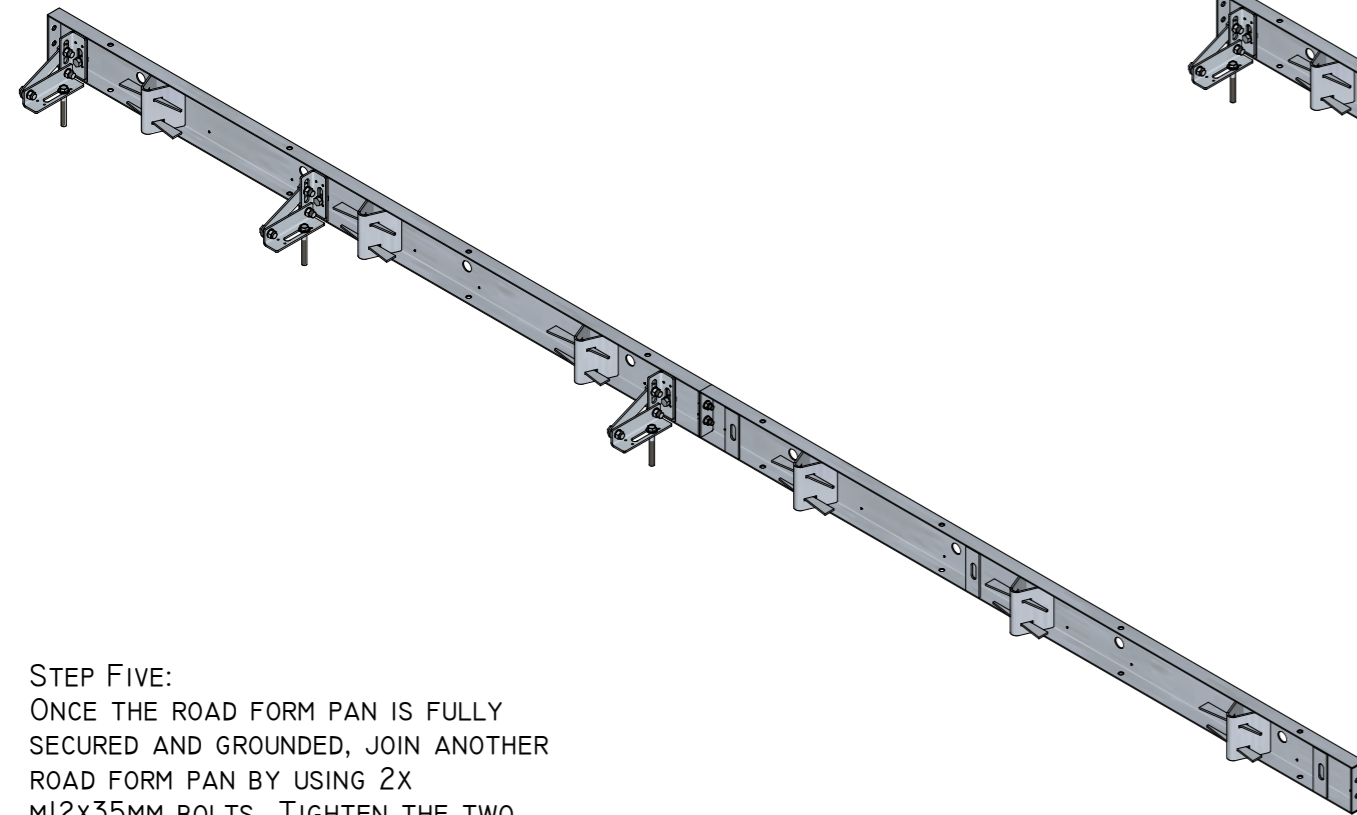

STEP FIVE:
ONCE THE ROAD FORM PAN IS FULLY SECURED AND GROUNDED, JOIN ANOTHER ROAD FORM PAN BY USING 2X M12X35MM BOLTS. TIGHTEN THE TWO BOLTS USING A SPANNER, MAKING SURE THEY ARE WELL FASTENED.

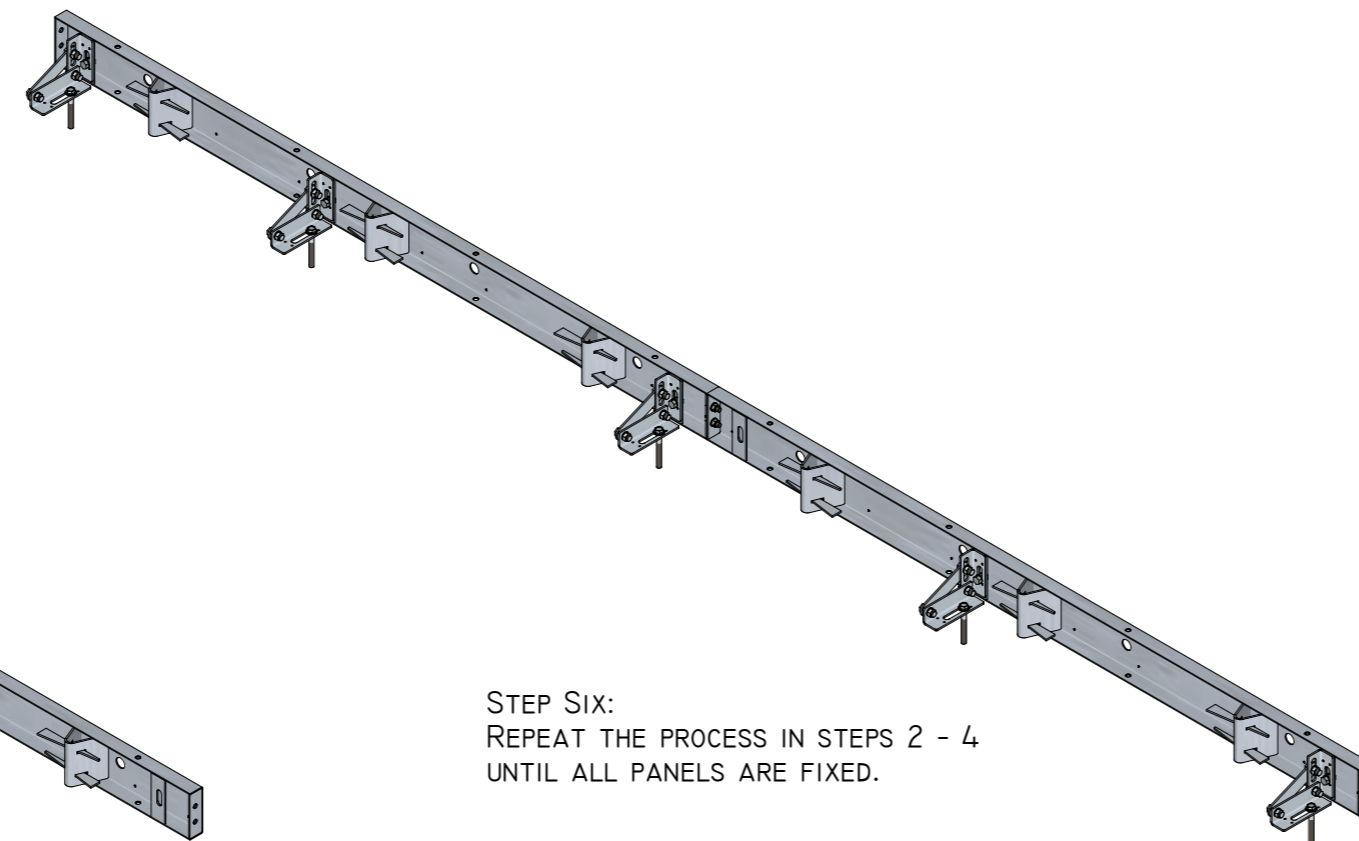

STEP SIX:
REPEAT THE PROCESS IN STEPS 2 - 4 UNTIL ALL PANELS ARE FIXED.

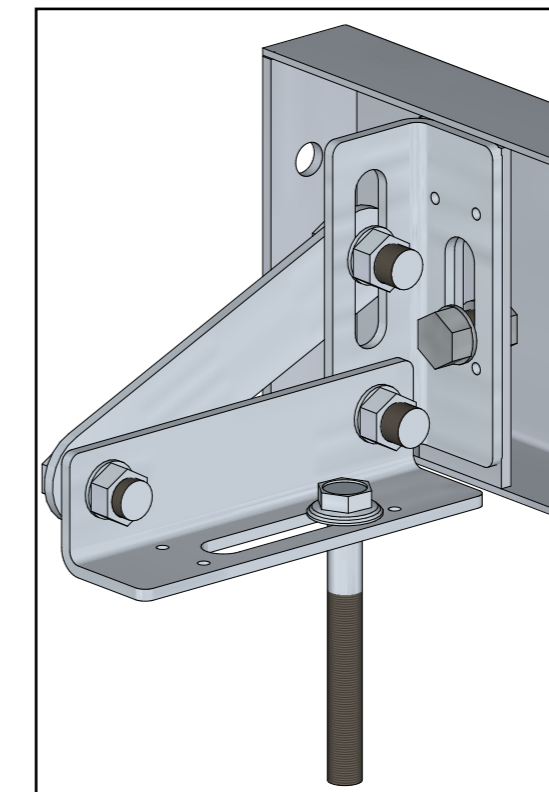

IMPORTANT



BE SURE TO CHECK GROUND SURVEY DRAWING AND CARRY OUT CAT SCAN TO LOCATE UNDERGROUND SERVICES BEFORE DRIVING PINS INTO THE GROUND

STACKING ROAD FORM PANS GUIDE

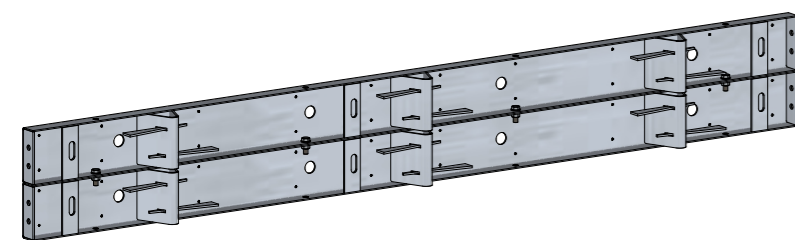

PLACE A ROAD FORM PAN ON TOP OF ANOTHER ROAD FORM PAN - REGARDLESS WHETHER THE ROAD FORM PAN IS 150MM OR 200MM HIGH, THE PROCESS REMAINS THE SAME - AND JOIN THEM TOGETHER USING 4x M12X35MM BOLTS. THE BOLTS MUST BE WELL SECURED AND TIGHTENED USING A SPANNER.

REPEAT THE PROCESS UNTIL ACHIEVED DESIRED HEIGHT. THE STACKED ROAD FORM PANS ARE TREAT AS A SINGLE ROAD FORM PAN/UNIT AND ALL ABOVE STEPS WILL APPLY TO IT NO DIFFERENT THEN BEING A SINGULAR ROAD FORM PAN.

CORRECT POSITIONING OF M12X35MM BOLTS

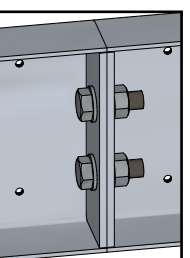
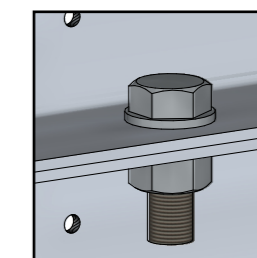

www.fastformsystems.com

info@fastformsystems.com

Tel South: 00 44 (0) 0203 507 1832 / 507 1833 / 507 1834

Tel North: 00 44 (0) 1472 488230 / 488660 / 485640



Head Office:
Unit 1
Omega Business Park
Estate Road 6
Grimsby
N.E.Lincs
DN31 2TG

Legal Notice:

Fast Form™ is the Trade Mark of Fast-Form Systems Ltd and all designs are copyright and intellectual property of Fast Form Systems Ltd and may not be reproduced or used without permission.
Fast Form™ is covered by the following Patents: granted GB2508263 / GB2533172 Patents Pending GB 1616005.3 / GB 1506126.0 / US-2016-0194887 / PCT WO2016 / 110663 / EP 14780541.0 / PCT GB2014 / 052586.
Copyright or Trade Mark infringements will be prosecuted, If you see any similar system in operation without our name on it please send us an email to info@fastformsystems.com, we offer a reward for all successful prosecutions.

Drawn By: Matt Jankowski

Date: 30/09/16

Rev: 0

Designed by: Karol Podsiadlo

Drawing no: FFS-RRF-RP

Project: Fast Form Road Form System

Drawing title: Rigid Road Form System Erection Step by Step Guide