

REVISION	DATE	DESCRIPTION	SIGNED
0	11/08/17	ORIGINAL VERSION	K.P.

BRACKET SYSTEM ERECTION STEP BY STEP GUIDE (BASE WITH FIXING TO HARDCORE)

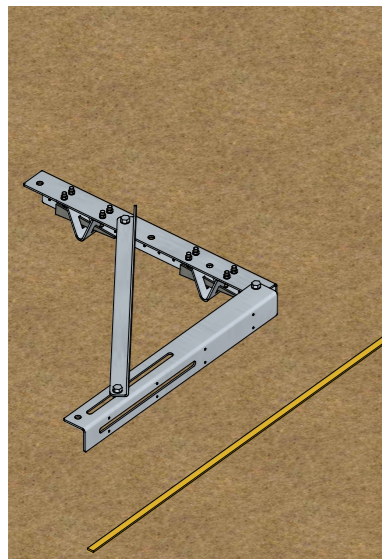

STEP ONE:
IMPORTANT
CHECK SURVEY DRAWINGS AND CAT SCAN AREA BEFORE DRIVING PINS INTO THE GROUND TO AVOID STRIKING ANY UNDERGROUND SERVICES

MARK LINE OF THE SHUTTER DEDUCTING THE PLY THICKNESS. FOR BRACKETS CENTRES SEE NOTE 3.

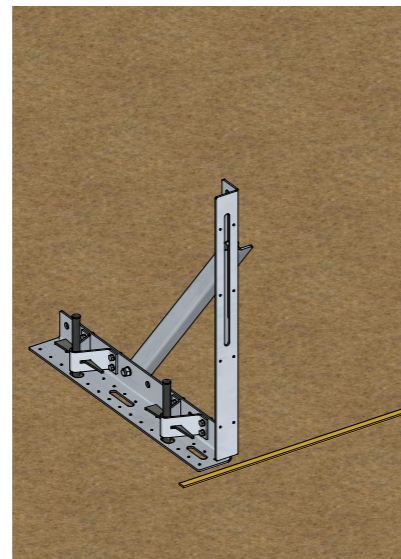

STEP TWO:
FIX DOWN THE FIRST BRACKET BY PLACING 2X ROAD PINS BETWEEN PIN BRACE AND WEDGE, CAREFULLY DRIVING INTO THE GROUND USING INSULATED LUMP HAMMER OR SLEDGE HAMMER. THE ROAD PINS MUST BE DRIVEN INTO THE GROUND SO THE BRACKET IS SECURELY FIXED. MAKE SURE TO LEAVE ENOUGH ROAD PIN OVERHANG SO IT CAN BE EXTRACTED USING AN EXTRACTION TOOL. TIGHTEN THE GRIP ON THE ROAD PINS BY TAPPING THE WEDGES USING A CLAW HAMMER.

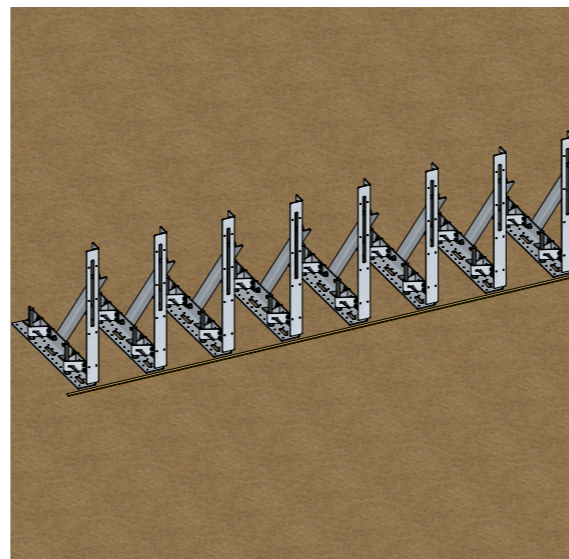

STEP THREE:
FIX DOWN ALL REQUIRED BRACKETS. FOR ALIGNING THE BRACKET SYSTEM PLUMB THE FIRST AND LAST BRACKET ONLY, LOOSEN THE BOLTS ON THE DIAGONAL MEMBERS OF THE REMAINING BRACKETS. ATTACH A STRING LINE TO THE TOP OF THE FIRST AND LAST BRACKET MAKING SURE IT IS TIGHT. ADJUST EACH BRACKET INDIVIDUALLY, BRINGING THE FACE OF THE UPRIGHT MEMBER TO THE STRING LINE BEFORE FULLY RE-TIGHTENING THE BOLTS WITH A TORQUE WRENCH RATED AT 220NM.

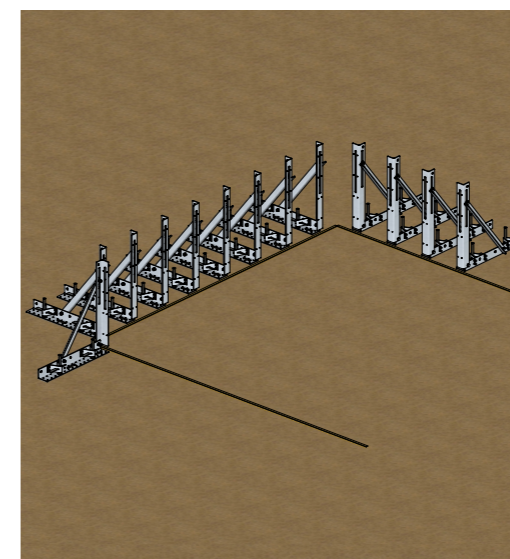

STEP FOUR:
CONTINUE THE PROCESS AROUND THE POUR OF THE SLAB. REMEMBER TO LEAVE SPACE FOR CORNER ACCESSORIES. IF IT'S A BEAM, SIMPLY REPEAT PREVIOUS STEPS FOR THE OTHER SIDE OF THE BEAM.

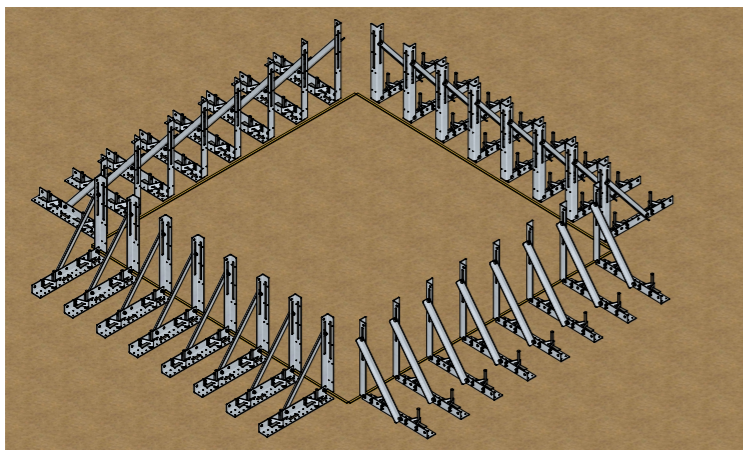

STEP FIVE:
AFTER ALL THE BRACKETS ARE SECURED, YOU ARE READY TO FIX THE PLYWOOD TO THE BRACKETS WITH SCREWS.

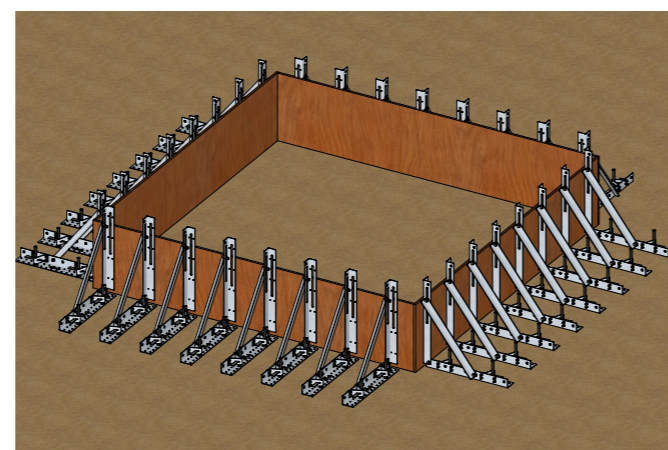

STEP SIX:
FIT ALL PLY (FROM BEHIND) USING 25MM WOOD SCREWS. PLY TO BE STRUCTURAL GRADE.

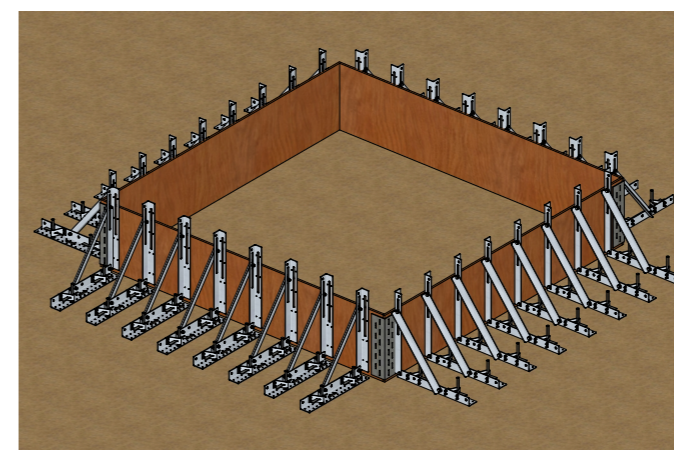

STEP SEVEN:
POSITION THE EXTERNAL CORNER ACCESSORIES IN PLACE AND FIX TO PLY USING ALL AVAILABLE HOLES.

NOTES:

THESE ARE STANDARD FITTING INSTRUCTIONS FOR THE FAST FORM BRACKET SYSTEM, YOU SHOULD BE ABLE TO COMPLETE ANY SIZE OR TYPE OF POUR FOLLOWING THESE:

1. START BY MARKING OUT THE LINE OF THE SHUTTER (REMEMBER TO DEDUCT THE PLY THICKNESS). REMEMBER TO CHECK SURVEY DRAWINGS AND CAT SCAN AREA BEFORE DRIVING PINS INTO THE GROUND TO AVOID STRIKING ANY UNDERGROUND SERVICES.
2. FIX DOWN FIRST BRACKET BY DRIVING ROAD PINS INTO THE GROUND [SEE STEP 2 FOR DETAILS].
3. CENTRES OF THE BRACKETS TYPICALLY TO BE NO MORE THAN 400MM FOR FAIR FACE FINISH. FOR CENTRES REFER TO THE DETAILED DRAWING OR SPECIFICATIONS FOR YOUR ORDER.
4. FOR CORNER CONSTRUCTION SET-UPS, PLEASE REFER TO DRAWING NO FFS-BSTC.
5. YOUR DESIGN MAY NOT INCLUDE TIE BARS AS THESE ARE GENERALLY NOT REQUIRED.
6. MOULD OIL / RELEASE AGENT SHOULD BE APPLIED TO THE FACE SIDE OF ALL PLY FOR EASY RELEASE AFTER CONCRETING.
7. STOP-ENDS TO BE DESIGNED AND SUPPLIED BY CLIENT.
8. IF ACCESS AND HANDRAILS HAVE BEEN REQUESTED BY THE CLIENT, THEY SHOULD BE FITTED BY A COMPETENT PERSON AND MADE SECURE BEFORE BEING USED AS A WORKING PLATFORM. THE ACCESS IS NOT LOAD BEARING AND SHOULD NOT BE USED FOR ANYTHING OTHER THAN ACCESS FOR CONCRETE POURING.
9. IF IN DOUBT OF ANYTHING PLEASE CALL OUR OFFICE, WE ARE HERE TO HELP.

LEGAL NOTICE:

Fast FormTM is the Trade Mark of Fast-Form Systems Ltd and all designs are copyright and intellectual property of Fast-Form Systems Ltd and may not be reproduced or used without permission. Fast FormTM is covered by the following Patents: granted GB2508263 / GB2533172 Patents Pending GB 1616005.3 / GB 1506126.0 / US-2016-0194887 / PCT W02016 / 110663 / EP 14780541.0 / PCT GB2014 / 052586. Copyright or Trade Mark infringements will be prosecuted, if you see any similar bracket in operation without our name on it please send us an email to info@fastformsystems.com we offer a reward for all successful prosecutions.

Drawn By: Karol Podsiadlo

Date: 11/08/17

Rev: 0

Designed by: Karol Podsiadlo

Drawing no: FFS-BSPBEG2

Project: Fast Form Bracket System

Drawing title: Bracket System Erection Step by Step Guide